

Mobil unit

GeoGo Clean

GeoGo Clean is a mobile air purification unit designed to clean the air of dust, aerosols, and other particles. It is used for air purification in any room, where you want a continuous cleaning of the air. It can be with practitioners, in meeting rooms, in offices or any other places where you want the air to be cleaned. It comes standard with an F7 and a HEPA 14 filter, which among other things cleans the air of viruses. Other solutions are available upon request.

The main benefits of GeoGo Clean are:

- A small and flexible extraction unit with a large capacity
- Filtration of the air with F7 filter which retains particles of the size of dust and larger
- The HEPA H14 filter retain pollutants like bacteria and viruses
- The turnable and easy running wheels gives an easy handling of the unit
- A potentiometer makes it easy to adjust the level of extraction. With a 0.17kW 230V fan, the device is efficient and long-lasting.

COVID-19 protection

We recommend that all guide lines and regulations of Ministry of Health and other official bodies will be followed when patients are treated. Measures like the use of face masks, eye protection, protective clothing etc. are obvious options. Extraction of air at the face of the patient is an additional opportunity, which is chosen in various applications. This kind of extraction will reduce the rate of pollutants that the patients, dentists and other persons are exposed to.

Dimensions

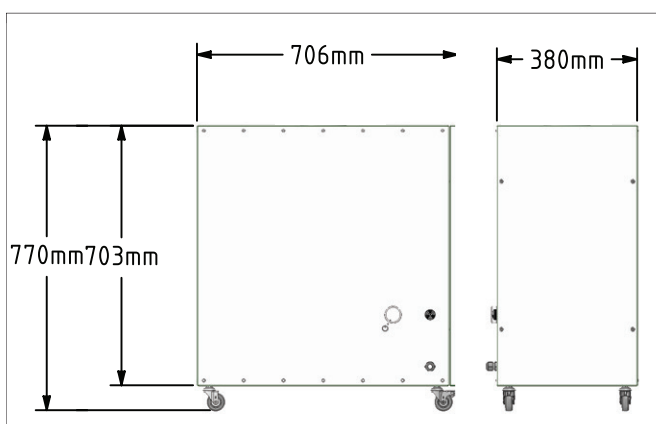

GeoGo Clean

Ordering table

Art. No.	Description
15-170	GeoGo Clean
15-196	Filter F7 for GeoGo Clean
15-197	Filter H14 for GeoGo Clean

Tekniske specifikationer

Model	GeoGo Clean
Current	230 V
Output	0,17 kW
Consumption	1,59 A
Filters	F7 / HEPA H14
Efficiency	99,995%
Class	H14
Filter area	F7: 1.9 m ³ H14: 4.3 m ³
Weight	55 Kg
Air flow	240 m ³ /h
Noise level	50% = 32 dB(A) 100% = 37 dB (A)