

## Workplace design

# GT Ultra Welding and grinding table

Geovent GT Ultra Welding and Grinding Table is used for welding and grinding applications.

The table is suitable for capturing both smoke and metal dust. The workpiece is placed on the table and the rear edge suction ensures that smoke and light particles are removed.

The GT Ultra welding and grinding table can be delivered in three variants. All three variants have back edge suction and flexible side doors as a standard.

If you choose the standard variant, you will get an efficient welding and grinding table with a blank table top. (Ref. No. 02-013)

If you choose a table with a grate as table top, heavier dust particles will fall through the grate and into the body of the table, from where they can be removed by e.g. a vacuum cleaner. (Ref. No. 02-014)

You can also choose a table with both a grate and a drawer to collect heavier dust particles. This table has suction under the grate. (Ref. No. 02-015)

The table comes partially assembled for easy handling and transportation.

The table is very user-friendly and can be fixed to the floor.

It can also be adjusted in height with great flexibility.

The sides can be swung out to create space for processing large workpieces.

The needed air flow for Ref. Nos. 02-013 and 02-014: 1800 m<sup>3</sup>/h.

The needed air flow for Ref. No. 02-015: 2000 m<sup>3</sup>/h.



02-015 GT Ultra Welding and grinding table with grilles and drawer

### Ordering table

Art. No.	Description
02-013	GT Ultra Welding and grinding table
02-014	GT Ultra Welding and grinding table with grate
02-015	GT Ultra Welding and grinding table with grate and drawer

### Dimensions

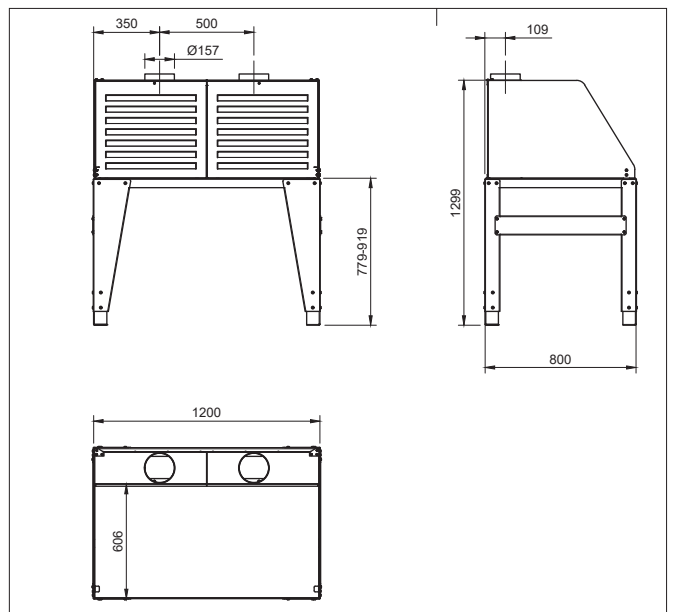

GT Ultra Welding and grinding table with swivel side panel